

Gas Generators



Athena
Technology

One Stop Laboratory Solution...



JAS-ANZ



Nitrogen Generator & Zero Air Gas Generator for GC& TOC



Salient Features:

- Deliver constant pressure & flow
- Easy Maintenance and space saving
- Improves instrument performance
- Fully regenerative, durability with PSA (pressure swing absorption) technology
- Fully Automatic Programmable System
- Effortless and easy operation

Technical Specification :

SPECIFICATIONS	Nitrogen Gas Specification of ATN-01 & ATN-02	Zero Air Specification of ATZ-01 & ATZ-02
Flow Rate Capacity of ATNA-01	500ml/min	4000ml/min
Flow Rate Capacity of ATNA-02	200ml/min	1500ml/min
ATN-02 (M)	500ml/min to 1000 LPM	5-1000 lpm
Pressure	5 kg/cm ² (bar) / 7 kg/cm ² (bar)	
Moisture	< 2 ppm	
Oxygen	<1 ppm	—
Total Hydro Carbon (THC)	< 0.3 ppm	
CO & CO ₂	< 2 ppm	
Purity	UHP / GC grade	
Micron particulates	< 0.01μ	
Method of Purification	Pressure Swing Adsorption (PSA) & Depressurizations	
Start up time	2 hr / programmable by timer	10 min
Electrical requirements	230 V AC, 50 Hz, 1 ph, 5 Amp	

Applications:

- GC-FID, FPD, NPD, TCD, AED
- GC-MS, LC-MS-MS, ICP / NMR
- FTIR/IR, ELSD detector
- Purging, Ampule Filling
- Analytical Grade
- Turbo Evaporator
- TOC Analyzer
- TOC Online Analyzer

High Capacity Nitrogen Gas Generator



Salient Features:

- Deliver constant pressure & flow
- Easy Maintenance and space saving
- Improves instrument performance
- Fully regenerative, durability with PSA (pressure swing absorption) technology
- Fully Automatic Programmable System
- Effortless and easy operation
- CE & ISO 9001:2008 Certified

Schematic Diagram of Gas Generator

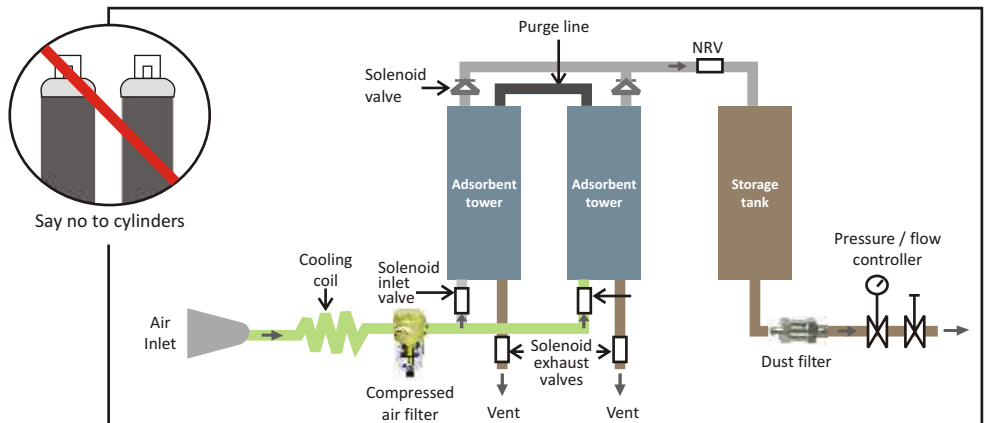

Nitrogen Generator for LC-MS / LC-MS-MS & Turbo Vap Evaporator

- Nitrogen Generator produces a continuous flow of high purity Nitrogen at selected pressure.
- The modular pressure swing adsorption (PSA) unit operates with alternating pressure increase and decrease.
- Untreated air flows under pressure through the reaction towers containing carbon molecular sieves adsorber. Moisture, CO, CO₂, THC, O₂ and other unwanted components in the air are adsorbed, leaving Nitrogen Gas of required purity.
- During the desorption cycle, the trapped substances adsorbed are released again at low pressure and the adsorber is ready for next cycle.
- Flow range available from 10 LPM to 30 LPM and above.

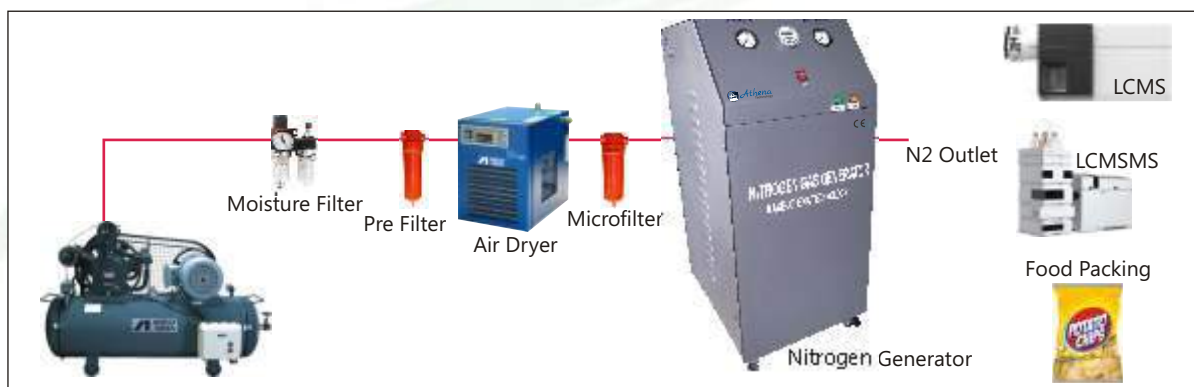

Technical Specification for N2 Generator for LC-MS & LC-MSMS :

Specifications	For LC-MS (TNG-02L)	For LC-MS-MS (TNG-02LS) (for Sciex model)
Flow rate Capacity of N2 Generator	6 to 30 LPM (as per selection of model)	12 LPM (filtered zero air)
		8 LPM (purified dry air)
		4 LPM (pure nitrogen)
Pressure	5 kg/cm ² or 100 psig or 60 psig	
Purity	99.99%	> 99.995%
Moisture	5 ppm	
Total Hydro Carbon	< 0.5 ppm	
CO & CO2	< 2 ppm	
Micro Particulates	< 0.01μ	
Method of purification	PSA - Pressure Swing Adsorption	
Room temperature	5°C	- 45°C
Startup time	1 hrs / programmable timer	
Electrical requirements	230 V AC, 50 Hz, 1 Ph, 2 Amp	

Technical Specification for N2 Generator for Turbo Evaporator & Food Packing

Specifications	For Turbo Evaporator (TNG-02T)	For Food Packing & Purging
Flow rate Capacity of N2 Generator	50 to 700 LPM (as per selection of model)	100 to 5000 LPM
Pressure	5 kg/cm ² or 100 psig or 60 psig	
Purity	>99% or 99.99%	
Moisture	100-200 ppm	
Total Hydro Carbon	< 10 ppm	
CO & CO2	< 10 ppm	
Micro Particulates	< 0.01μ	
Method of purification	PSA - Pressure Swing Adsorption	
Room temperature	5°C - 45°C	
Startup time	1 hrs / programmable timer	
Electrical requirements	230 V AC, 50 Hz, 1 Ph, 2 Amp	
Net Weight (without compressor) (approx.)	100 kg - 200 kg (as per selection of model)	

ZERO AIR GENERATOR for GC, TOC & Online TOC

Technical Specification

Principle	ATZ-01 (for 2-5 GC's) (for Imported GC)	ATZ-02 (for TOC Analyzer)	ATZ-03 (for Online Specifications TOC Analyzer)
Moisture	< 2 ppm	< 0.5 ppm	<1 ppm
Total Hydro Carbon	< 0.5 ppm	< 0.2 ppm	< 0.5 ppm
CO & CO2	< 2 ppm	< 0.2 ppm	<1 ppm
Purity	GC/UHP grade	TOC/XL grade Online	TOC Grade
Micro Particulates		< 0.01μ	
Capacity of ZAG	4 LPM at 5kg/cm ²	500 ml/min at 5kg/cm ²	1 LPM at 5kg/cm ²
Method of purification	Pressure Swing Adsorption (PSA)	Pressure Swing Adsorption (PSA) & HC Cracking furnace	Pressure Swing Adsorption (PSA)
Room temperature	5 °C - 25 °C		
Start up time	5 minutes	30 minutes	5 minutes
Electrical requirements	230 V / 110V AC, 60 /50 Hz, 1 ph		
for ZAG	4 Amp	5 Amp	4 Amp

- Zero Air Generator for TOC Analyzer produces a continuous flow of high purity Zero Air at selected pressure.
- System has built in moisture separator with Air Filter & Desiccant Air Dryer
- The modular pressure swing adsorption (PSA) unit operates with alternating pressure increase and decrease.
- Untreated Air Flows under pressure through the reaction towers containing molecular sieve adsorber .
- Moisture, CO, CO2, THC and other unwanted components in the air are adsorbed, leaving Zero Air Gas of required purity.
- The Zero Air Generators are suitable for use in laboratories for Online TOC Analyzer.

Salient Features:

- Deliver constant pressure & flow
- Fully Automatic Programmable System
- Easy Maintenance and space saving
- Effortless and easy operation
- Improves instrument performance
- Fully regenerative, durability with PSA technology

Hydrogen Gas Generator



- Hydrogen is produced in the ATH Series Hydrogen Generators by the most advanced electrolytic membrane technology.
- The application of voltage across the electrolyte results in hydrolysis, breaking down the water molecule into hydrogen and oxygen gas, which are separated by the gas permeable membrane.
- Once separated, the hydrogen gas goes through a series of purification and moisture removal systems to achieve the desired level of purity while the oxygen gas is being discharged into the atmosphere.
- Electrolytic membrane technology has its advantages over alternative hydrogen generating techniques as it is clean, requires less maintenance and there is no need to store chemicals to maintain operation.
- Only pure double distilled water (initially some KOH), is required to provide trouble free long term operation.
- Membrane separation is also less time consuming as only water is needed for routine maintenance.

	ATH-300	ATH-500	ATH-1000
Max Hydrogen Flowrate	300 ml/min	500 ml/min	1000 ml/min
Delivery Pressure	0-60 psig (0-4 kg/cm ² or 0-7 bar)		
Purity	>99.999% or 99.9999%		
Power Consumption	150 W	180 W	220 W
Power	198-242V (AC); 50Hz, 1 Phase		
Min/max Temperature	5-40°C		
Max. Ambient Humidity	<85% RH		
Suitable Environment	non-corrosive and dust-free		
Dimensions	420 x 210 x 350mm (LxWxH)		
Weight	12 kg (approx) & 15 Kgs		
Fluid Tank Capacity	1.5 L, 2.5 L, & 3.5 L		
Fluid Consumption	Weekly or when level falls below 0.6		

Note: Higher capacity model also available like 2 LPM & 3 LPM

Applications:

Instruments	Gas Requirement	Purity	Flow Rate	Generator Recommendation
Products for Gas Chromatography				
GC-FID	Hydrogen for fuel gas	UHP Hydrocarbon-free	30-50 cc/min	Hydrogen
	Hydrogen for capillary	UHP, Zero grade	up to 10 cc/min	Hydrogen
GC-FPD	Hydrogen for fuel gas	UHP	60-90 cc/min	Hydrogen
GC-NPD	Hydrogen for capillary gas	UHP	up to 50 cc/min	Hydrogen
GC-TCD	Hydrogen as carrier gas	UHP	up to 50 cc/min	Hydrogen
GC-ELCD	Hydrogen as reaction gas	UHP	70 to 200 cc/min	Hydrogen
Products for Analyzers				
THA	Hydrogen for fuel gas	UHP	5 to 50 cc/min	Hydrogen

- Hydrogen Generators provide an onsite supply of hydrogen gas, eliminating the need of gas cylinders, which can be bulky and require special cylinder storage space. They provide ultra-high purity hydrogen gas.
- power on to produce gas.
- High reliability, easy to maintain. Match with all kinds of GC.



Athena
Technology

ATHENA TECHNOLOGY

802, Hercules, Lodha Paradise, Majiwada, Thane (W) - 400 601 INDIA

Mob: +91 8879902481 / 9769047445 / 9821488400

Email: info@athenatechnology.co.in / milan@athenatechnology.co.in

Web: www.athenatech.in • www.athenatechnology.co.in

www.nitrogenevaporator.com • www.nitrogenevaporator.in

