

*One Stop Laboratory Solution...*

# Lab Gas Generators



- High Reliability & Easy for Operation
- Compact Size
- Best Quality & Better Performance
- Over 500+ Installation in India & Internationals
- CE, ISO, FDA approved

Athena Technology, an ISO 9001: 2015 Certified Company is a reputed manufacturer, exporter and trader of high quality scientific instruments and laboratory equipments. Our unparalleled array of products includes Nitrogen Evaporator, Nitrogen Gas Generator, Zero Gas Generator and Hydrogen Gas Generator.

Under the brand name Athena, our products are known for their high efficiency, unmatched reliability, high durability, proven performance.



- Safe and convenient
- Compact structure.
- Take up very little laboratory space.
- Nitrogen generators supply ideal ultra pure nitrogen for GC (Gas Chromatography), LC/MS (Liquid Chromatograph / and Thermal Analyzer).
- Continuously generate ultra pure nitrogen through Pressure Swing Adsorption (PSA) technology.
- No longer need to use inconvenient and dangerous high pressure nitrogen cylinders in laboratory.

# Nitrogen Gas Generator GC



- N2 purifier to remove O2 and all other unwanted impurities to produce nitrogen up to UHP grade.
- Automatic heatless air dryer time based operation.
- Surge receiver with pressure regulator & valve inbuilt.
- Nitrogen, air gas with regulator, gauge and toggle valve (inbuilt) SS tank.
- Air filters for moisture, dust and oil, must removal (set of 2 filters).

### Silent Features:

- Deliver constant pressure & flow
- Fully Automatic Programmable System
- Easy Maintenance and space saving
- Effortless and easy operation
- Improves instrument performance
- CE & ISO 9001:2015 FDA Certified
- Fully regenerative, durability with PSA (pressure swing adsorption) technology
- CAD Detector

### Schematic Diagram of Gas Generator

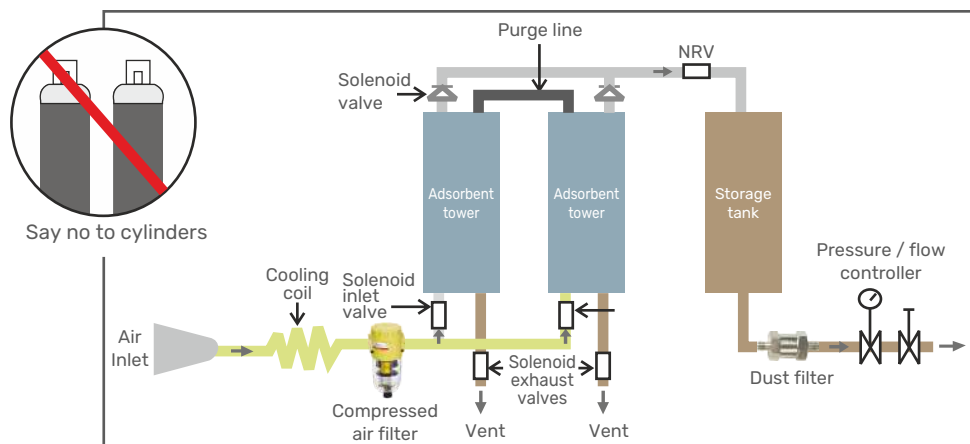

### Technical Specification

Model	Gas Output	Flow rate	Application
ATN-02	Nitrogen Gas Generator	<b>Flow:</b> N2 = 200 ml/min <b>Purity:</b> 99.999% <b>Pressure:</b> 7 bar	For 2 GCs Gas Chromatographs
ATN-05	Nitrogen Gas Generator	<b>Flow:</b> N2 = 500 ml/min <b>Purity:</b> 99.999% <b>Pressure:</b> 7 bar	For 5 GCs Gas Chromatographs

# Nitrogen + Air Combination Gas Generator for GC

Nitrogen Generator uses PSA technology to separate N<sub>2</sub> from the Air, whole Athena equipment is control by the programs. The Flow output & pressure of N<sub>2</sub> are quite stable, The physical method to produce Nitrogen by PSA technology. The Nitrogen generator has advantages of no pollution, no corrosion. It could longer GC lifetime. It is very safety to use, longer life time, stable quality, and very easy to use. It could completely meet requirement for kinds of GC.



## Silent Features:

- It can replace the high pressure nitrogen cylinder to make the laboratory instrumented and ensure the safety.
- Automatic control of working process, simple operation and convenient daily maintenance.
- Digital display of nitrogen production is convenient for observing instrument working state and fault judgment.
- Long service life, continuous or intermittent use, stable gas production and no attenuation.
- Program controlled intelligent self diagnosis function and service prompt function, easy to maintain.
- Highly integrated modular structure design, saving laboratory space.
- The system has built-in pressure stabilizing unit of air storage tank and safety valve design with international standards.
- Movable design with caster, easy to facilitate move.

## Machine Characters:

- Two CMS tower, with world top quality molecular sieve from Japan.
- Stainless steel gas tank inside to guarantee gas purity.
- Two levels pressure stable valves to guarantee very stable output pressure.
- Three levels gas purification system to guarantee very high output purity.
- Flow and pressure are both adjustable. Gas produced on demand.
- Continuously generate ultra-pure nitrogen through Pressure Swing Adsorption (PSA) technology.
- Compressor inside, no needing any external air source.
- Produce ultra pure nitrogen for GC (Gas Chromatography), LC/MS (Liquid Chromatograph / Mass Spectroscopy) and Thermal Analyzer.

## Technical Specification

Model	Gas Output	Flow rate	Application	
ATNA-05	Nitrogen + Air Combination Gas Generator	<b>Flow:</b> N <sub>2</sub> = 500 ml/min <b>Air</b> = 5000 ml/min <b>Purity:</b> 99.999% <b>Pressure:</b> 7 bar	For 5 GCs Gas Chromatographs	GC-FID GC-FPD GC-NPD GC-ECD GC-TCD
ATNA-02	Nitrogen + Air Combination Gas Generator	<b>Flow:</b> N <sub>2</sub> = 200 ml/min <b>Air:</b> 2000 ml/min <b>Purity:</b> 99.999% <b>Pressure:</b> 7 bar	For 2 Gcs Gas Chromatographs	GC-ATD AT-AED GC-ELSD

# Nitrogen Gas Generator for LC-MS



- Nitrogen Generator produces a continuous flow of high purity N<sub>2</sub> at selected pressure
- The modular pressure swing adsorption (PSA) unit operates with alternating pressure of increase and decrease the function.
- Untreated air flows under pressure through the reaction towers containing carbon molecular sieves adsorber.
- O<sub>2</sub>, CO, Co, THC, Moisture and other unwanted components in the air are adsorbed, leaving Nitrogen Gas of required purity.
- During the desorption cycle, the trapped substances adsorbed are released again at low pressure and the adsorber is ready for next cycle.
- Flow range available from 10 LPM to 65 LPM and above.

## Technical Specification

Model	Gas Output	Flow rate	Application	
ATN-LCMS1	Nitrogen Gas Generator	<b>Flow:</b> N <sub>2</sub> + 6LPM-40LPM <b>Purity:</b> MS Grade <b>Pressure:</b> 7 bar	N <sub>2</sub> Generator compatible with most of the LC-MS instrument	Suitable for most of the LC-MS instrument
ATN-LCMS2	Nitrogen Gas Generator	<b>Flow:</b> N <sub>2</sub> = 65LPM <b>Purity:</b> MS Grade <b>Pressure:</b> 7 bar	N <sub>2</sub> Generator developed for LC-MS instruments with require higher flow rates	N <sub>2</sub> supply for range of laboratory application including LC-MS



## Product Features

### System integration

- Integrated compressed air and purification system

### High reliability

- Mature technology
- High quality components
- Optimised design to ensure the excellent N<sub>2</sub> quality.

### Cost saving

- Low operation cost 7x24h continuously running

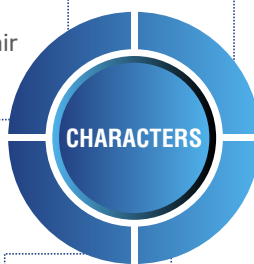

### Easy for operation

- Optimised structure, compact design
- Plug and play

### Easy for operation

- Intelligent evacuation of unqualified nitrogen to realize unattended

### Unique materials selection

- Adsorption canister uses astronautics sophisticated aluminum profile, treated with anodic oxidation

# Nitrogen Gas Generator for LC-MS-MS

- Outlet Flow N2: 20LPM
- Outlet Pressure N2: 7bar (kg/cm<sup>2</sup>) 100 psi
- Purity: 99.9%
- Purity: UHP / LCMS Grade
- Micro Particulate: Nil
- Outlet Connection: 1/4" OD
- Method of Purification: Pressure Swing Adsorption Technologies
- PSA & Depressurisation
- Valves: PLC based Pneumatic 2 way
- Tank received attached backside of N2 generator
- With In-built Oil Free Air Compressor for above generator
- The Nitrogen gas generator should be based on pressure swing adsorption (PSA) technology with two columns should operate alternately in adsorption & desorption cycle to produce a continuous supply of Laboratory Grade Nitrogen 24 hour a day.



## Technical Specification

Model	Gas Output	Flow rate	Application	
ATN-LCMSMS1	Nitrogen Zero Air Curtain Dry Air Gas	<b>Nitrogen:</b> 4 LPM <b>Zero Air:</b> 12 LPM <b>Dry Air:</b> 8 LPM <b>Purity:</b> MS grade <b>Pressure:</b> 7 bar	Suitable for selected Sciex LC-MS instrument LC-MS	API/LCMS/APCI Electrospray LCMC/MS, TOF
ATN-LCMSMS1	Nitrogen Zero Air Curtain Dry Air Gas	<b>Nitrogen:</b> 12 LPM <b>Air:</b> 24 LPM <b>Dry Air:</b> 14 LPM <b>Purity:</b> MS grade <b>Pressure:</b> 7 bar	Suitable for all Sciex LC-MS instruments	Air for nebulizer gas nitrogen for curtain and sheath shield gas
ATN-LCMSMS3	Nitrogen Zero Air Curtain Dry Air Gas	<b>Nitrogen:</b> 24 LPM <b>Zero Air:</b> 48 LPM <b>Dry Air:</b> 32 LPM <b>Purity:</b> MS grade <b>Pressure:</b> 7 bar	Suitable for selected LC-MS-MS instruments with the requirement high flow	



# Zero Air Generator For GC & TOC



- Zero Air Generator for TOC Analyzer produces a continuous flow of high purity Zero Air at selected pressure.
- System has built in moisture separator with Air Filter & Desiccant Air Dryer
- The modular pressure swing adsorption (PSA) unit operates with the alternating pressure increase and decrease.
- Untreated Air Flows under pressure through the reaction towers containing molecular sieve adsorber
- Moisture, CO, CO<sub>2</sub>, THC and other unwanted components in the air are adsorbed, leaving Zero Air Gas of required purity.
- The Zero Air Generators are suitable for use in the laboratories for Online TOC Analyzer

## Silent Features:

- Deliver constant pressure & flow
- Fully Automatic Programmable System
- Easy Maintenance and space saving
- Effortless and easy operation
- Improves instrument performance
- CE & ISO 9001:2015 FDA Certified
- Fully regenerative, durability with PSA (pressure swing adsorption) technology

## Applications:

- GC-FID, FPD, NPD, TCD, AED
- GC-MS, LC-MS-MS, ICP / NMR
- FTIR/IR, ELSD detector
- Purging, Ampule Filling
- Analytical Grade
- Turbo Evaporator
- TOC Analyzer
- TOC Online Analyzer

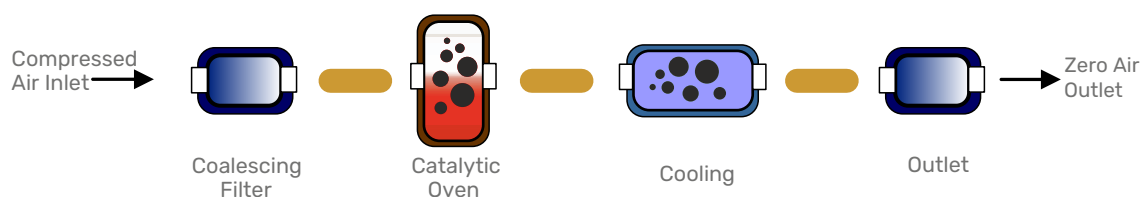

## Technical Specification

Model	Gas Output	Flow rate	Application	
ATZ-05	Zero Air Gas Generator	<b>Flow:</b> Air = 5000ml/min <b>Purity:</b> 99.999% <b>Pressure:</b> 5-6 bar	For 5 GCs Gas Chromatographs	GC-FID,GC-FPD GC-NPD,GC-ECD GC-TCD,GC-ATD AT-AED,GC-ELSD THA, DSC Air, TGATOD, CO2 Analyzer Sample Prep Autosamplers ELSD Detector Particle sizing by Laser Diffraction TOC
ATZ-02	Zero Air Gas Generator	<b>Flow:</b> Air = 2000ml/min <b>Purity:</b> 99.999% <b>Pressure:</b> 5-6 bar	For 2 Gcs Gas Chromatographs	
ATZ-T	Zero Air Gas Generator	<b>Flow:</b> Air = 4000ml/min <b>Purity:</b> 99.999% <b>Pressure:</b> 5-6 bar	For TOC Analyzer Gas Chromatographs	

# N2 & H2 & Air Combination Gas Generator

Athena N2 & H2 & Air generators achieve the perfect combination of nitrogen, hydrogen and Air. Compact structure and easy operation make it the ideal gas generator. This product can be applied to various gas chromatography and analysis instruments at home and abroad. N2 & H2 & Air Generator has the characteristics of three-in-one, three-in-one, compact design and simple operation. It is an ideal laboratory instrument to replace traditional cylinder gas.

## Applications:

- Petroleum
- Pesticide
- Tobacco Power Generation
- Wine Making
- Environmental Monitoring
- Universities
- Other Departments Monitoring
- Chemical
- Fertilizer
- Drug Testing
- Water Quality Testing
- Disease Control Centres
- Research Institutes
- Indoor Environmental Monitoring

## Silent Features:

- Start the switch, safe and reliable.
- Adjusted automatically
- Anti-liquid device
- LED digital display
- Anti-impact anti-aging filter
- High purity of gas
- One-time addition of alkali,
- Automatic drainage
- Stainless steel gas storage tank
- Can be used for 24 hours in a row
- Preferable in gas chromatographs at home and abroad.
- It can replace traditional high pressure cylinders.
- Easy to operate
- Pressure stability
- Low noise and strong purification ability
- System three-stage filtration (no oil)
- Long service life and easy maintenance



## Technical Parameters

Model:	AT-NAH-300
Nitrogen Outflow:	0~300 ml/min
Air Outflow:	0~2000 ml/min
Hydrogen Outflow:	0~300 ml/min
H2, N2 Air output pressure:	5 kg/cm <sup>2</sup> (0-60 psig)
Air output pressure:	0~4 kg/cm <sup>2</sup> (0-60 psig)
H2/N2/Air purity:	99.999%
Moisture:	< 2 ppm
Oxygen:	< 3ppm
Voltage:	~220V±10% 50Hz
Power:	450W
Water tank:	H2 2.5 liters
Ambient temperature:	5°~40°
Hydrogen Technology:	Electrolysis Process
Weight:	40 kgs
Hydrogen technology:	SPE / PEM
N2 & Air technology:	PSA (Pressure Swing Adsorption)
Water Quality Demand:	Deionized water or Double distilled water



# Nitrogen Gas Generator for FTIR / ELSD / CAD



## Features:

- Safe and convenient
- Compact structure. Take up very little laboratory space.
- Nitrogen generators supply ideal ultra pure nitrogen for ELSD, CAD Detector, FTIR, GC (Gas Chromatography), LC/MS (Liquid Chromatograph / Mass Spectroscopy) and Thermal Analyzer.
- Continuously generate ultra pure nitrogen through Pressure Swing Adsorption (PSA) technology. No longer need to use inconvenient and dangerous high pressure nitrogen cylinders in laboratory.

## Why Choose Athena Nitrogen Generator Units:

- Warranty 2 years
- Extensive experience in manufacturing the PSA and membrane units
- All the ATHENA Group's facilities are CE, FDA, ISO 9001:2015 Certified
- Modular design for easy installation
- Systems designed for long-term reliability & availability of smallest physical footprint available
- Strategic alliance with dryer and compressor suppliers
- Extensive global service network ATHENA Group has a top-rated PSA & membrane technology when comparing nitrogen / air ratio
- We manufacture gas generators for many specialist applications including FT-IR. Our PG range of Purge Gas generators provide CO<sub>2</sub> free gas which is ideal for FT-IR analysis
- Nitrogen generators which are suitable for ELSD and CAD applications

## Technical Specification

Model	Gas Output	Flow rate	Application
ATN-FTIR	Nitrogen Gas	<b>Flow:</b> 15 lpm <b>Purity:</b> 99.99% <b>Pressure:</b> 7 Bar	FTIR Instrument
ATN-ELSD	Nitrogen Gas	<b>Flow:</b> 10 lpm <b>Purity:</b> 99.5% <b>Pressure:</b> 7 Bar	ELSD
ATN-CAD	Nitrogen Gas	<b>Flow:</b> 10-30 lpm <b>Purity:</b> 99.9% <b>Pressure:</b> 7 Bar	CAD Detector

# Nitrogen Generator for N2 Evaporator / Turbovap/ SPE Processor

We ATHENA TECHNOLOGY, are the Manufacturer & Exporters of High-Quality PSA Nitrogen Gas plants from India. Our PSA Nitrogen Gas Plants are of high quality working on the renowned PSA Technology & pertaining industry standards. If you are looking for pure Nitrogen, you need is to select best PSA nitrogen gas generator. Nitrogen purity in the range of 99% to 99.9999% can be achieved through our nitrogen gas generators & Plants. Our PSA nitrogen gas generator produces raw nitrogen of 99% to 99.99% purity. Our Nitrogen Plant operates on PSA technology, consists of twin tower system filled with special grade of carbon molecular sieves (C.M.S.) at a time, one tower keeps in production cycle and other in regeneration cycle. When compressed air passed through C.M.S. bed, the molecules of oxygen, moisture & other unwanted gases are adsorbed on the surface of C.M.S. and the nitrogen which is not adsorbed by C.M.S comes out of the adsorption tower and is collected in a surge vessel.

Nitrogen Generator Model ATN-P for Purging, in SPE processors, Pharma Applications, Nitrogen Concentrator, Turbovap Evaporator.

- N2 Purifier to remove O2 and all other unwanted impurities
- To produces Nitrogen upto HP grade.
- Automatic Heatless Air dryer time based operation Surge receiver with pressure regulator & valve inbuilt Nitrogen, Air gas with regulator, Gauge and toggle valve (inbuilt) SS tank
- Air filters for moisture, dust and oil, mist removal (set of filters)
- Compact size
- Capable of supplying multiple instruments
- 24/7 operation at optimum performance
- Lower maintenance requirement and ensures long life of the generator
- Completely silent in operation.
- Automatic drain system
- Automatic purging moisture system

The Nitrogen gas generator be based on pressure swing adsorption (PSA) technology with two columns of CMS molecular sieve absorber. The two columns operate alternately in adsorption & desorption cycle to produce a continuous supply of grade nitrogen 24 hours a day



Specifications	For Purging in Nitrogen Evaporator (ATN-P)
Flow rate capacity of N2 Generator	75-5000 lpm (for 25, 50, 100, 144 Sample Nitrogen Evaporator & SPE Processor) (5 <sup>3</sup> -100nm <sup>2</sup> /hr)
Pressure	1-8 kg/cm <sup>2</sup> or 10 psig- 100 psig (Settable)
Purity	>99% (as per requirement)
Gas Outlet	Nitrogen
N2 Outlet Connection	¼"
Total Hydro Carbon	< 10 ppm
CO & CO2	< 10 ppm
Micro Particulates	< 0.01 µm
Method of purification	PSA-Pressure Swing Adsorption
Room temperature	5°C - 45°C
Startup time	30 mins / programmable timer
Electrical requirement	230 V AC, 50 Hz, 1 Ph, 2 Amp



Capacity 100 LPM to 10000 LPM



Nitrogen Generator



Evaporator



SPE

# Membrane Nitrogen Gas Generator



- Extensive experience in producing PSA and membrane units
- All the ATHENA Group's facilities are ISO 9001:2015 Certified
- Modular design for easy installation
- Systems designed for long-term reliability
- Smallest physical footprint available
- Strategic alliance with dryer and compressor suppliers
- Extensive global service network
- ATHENA Group has a top-rated membrane when comparing nitrogen/air ratio

The ATHENA Membrane module contains over one million fibers that selectively remove oxygen and water vapor from compressed air, which enters one end of the membrane module. The enriched nitrogen product flows continuously from the other end of the module where it can be used in production, blanketing, or captured for storage.

ATHENA membranes combine the best available membrane materials with state-of-the-art fiber bundling and the optimum module fabrication methods to provide the most cost-effective solution for on-site gas separation production....and we have over 20 patents to prove it!

## Typical System Configuration (PFD)

The process flow diagram below provides a basic system description of the Nitrogen Membrane Generator. A detailed P&ID will be provided for the exact project once all the system options have been established.

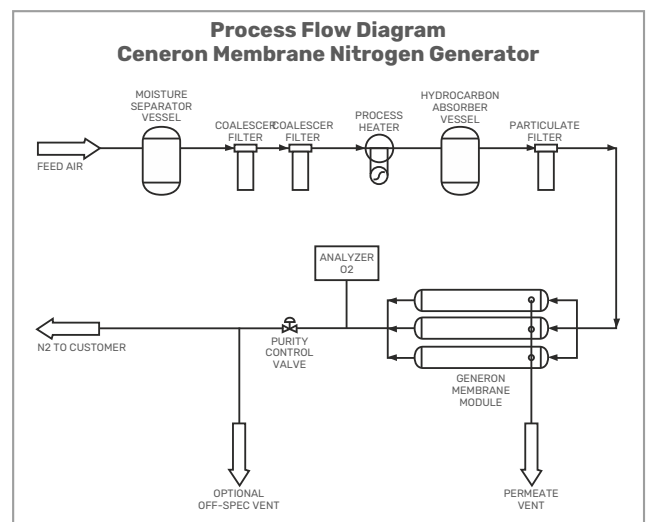
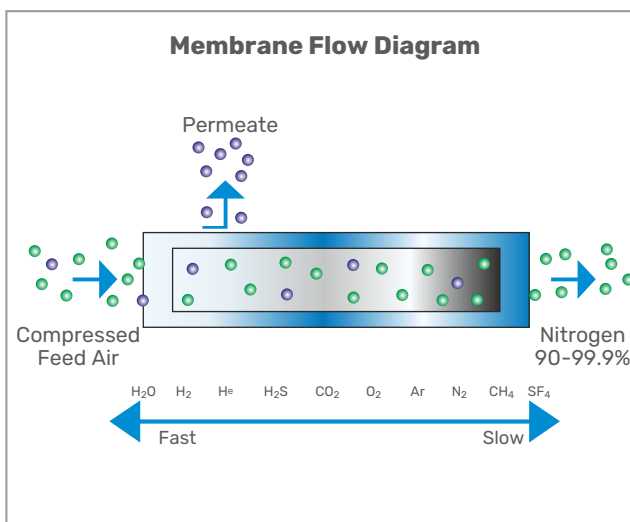

# Hydrogen Gas Generator

## Working Principle:

- Hydrogen is produced in the ATH Series Hydrogen Generators by the most advanced electrolytic membrane technology.
- The application of voltage across the electrolyte results in hydrolysis, breaking down the water molecule into hydrogen and oxygen gas, which are separated by the gas permeable membrane.
- Once separated, the hydrogen gas goes through a series of purification and moisture removal systems to achieve the desired level of purity while the oxygen gas is being discharged into the atmosphere.
- Electrolytic membrane technology has its advantages over alternative hydrogen generating techniques as it is clean, requires less maintenance and there is no need to store chemicals to maintain operation.
- Only pure double distilled water (initially some KOH), is required to provide trouble free long term operation.
- Membrane separation is also less time consuming as only water is needed for routine maintenance.



	ATH-300	ATH-500	ATH-1000
Max Hydrogen Flow rate	300 ml/min	500 ml/min	1000 ml/min
Delivery Pressure	0-60 psig (0-4 kg/cm <sup>2</sup> or bar)		
% purity	>99.999%		
Power Consumption	150 W	180 W	220 W
Power	198-242V (AC); 50Hz, 1Phase		
Min/max Temperature	5-40°C		
Max. Ambient Humidity	<85% RH		
Suitable Environment	non-corrosive and dust-free		
Dimensions	420 x 210 x 350mm (LxWxH)		
Weight	12 kg (approx)		
Fluid Tank Capacity	1.5 L		
Fluid Consumption	Weekly or when level falls below 0.6		

**Note:** Higher capacity model also available like 2 LPM & 3 LPM

## Applications:

Instruments	Gas Requirement	Purity	Flow Rate	Generator Recommendation
<b>Products for Gas Chromatography</b>				
GC-FID	Hydrogen for fuel gas	UHP Hydrocarbon-free	30-50 cc/min	Hydrogen
	Hydrogen for capillary	UHP, Zero grade	up to 10 cc/min	Hydrogen
GC-FPD	Hydrogen for fuel gas	UHP	60-90 cc/min	Hydrogen
GC-NPD	Hydrogen for capillary gas	UHP	up to 50 cc/min	Hydrogen
GC-TCD	Hydrogen as carrier gas	UHP	up to 50 cc/min	Hydrogen
GC-ELCD	Hydrogen as reaction gas	UHP	70 to 200 cc/min	Hydrogen
<b>Products for Analyzers</b>				
THA	Hydrogen for fuel gas	UHP	5 to 50 cc/min	Hydrogen

Hydrogen Generators provide an onsite supply of hydrogen gas, eliminating the need of gas cylinders, which can be bulky and require special cylinder storage space. They provide ultra-high purity hydrogen gas. The ATH Series Hydrogen Generator have been used in a wide variety of applications such as general industrial, military, wastewater treatment and especially in laboratory gas chromatography. ATH Hydrogen Generators employs the most advance velum separation technology for the electrolytic production of hydrogen gas.

Easy to operate, safe and reliable, generating hydrogen through electrolyzing pure water, switching power on to produce gas.

High reliability, easy to maintain. Match with all kinds of GC.



## 1100 lpm to 50000 lpm (61 nm<sup>3</sup>/hr to 3000 nm<sup>3</sup>/hr)

Nitrogen gas has been used for decades in the food packaging industry to help preserve the freshness, integrity and quality of the packaged product. Nitrogen can provide benefits in main packaging types:

- Bags
- Bottles
- Boxes
- Cans
- Plastic containers

Nitrogen Gas is being increasingly used in the processed food industry and specially for packaging purposes. Nitrogen has long been used in the food packaging industry to help preserve the freshness, integrity and quality of the delivered product. Food packaging types include: bags, bottles, cans, boxes, plastic or card board containers. Manufacturers often

use a Nitrogen gas purge to displace oxygen from the packaging before sealing it closed. The presence of oxygen introduces moisture which can deteriorate the food quality. Using Nitrogen purge food packaging of oxygen is a safe practice widely used throughout the food industry.

Nitrogen Generator, Athena Technology Nitrogen Generation Technology is a safe, reliable and cost effective alternative to high pressure N<sub>2</sub> cylinders. We explore the benefits of Nitrogen gas for snack food packaging application.

## Capacity of Plant

Flow:	100 lpm to 10000 lpm 6 nm <sup>3</sup> /hr to 6000 nm <sup>3</sup> /hr
Purity:	97% to 99.99%
Pressure:	0 - 7 bar
PSA Pressure	Swing Adsorption Technology

## Applications

- Food packaging (cheese, salami, coffee, dried fruit, herbs, fresh pasta, ready meals, sandwiches, etc. ...)
- Bottling wine, oil, water, vinegar
- Fruit and vegetable storage and packing material
- Industry
- Medical
- Chemistry
- PSA Nitrogen Generator System is used worldwide.
- Food packing, Food storing, Electric & Electronic industry, Petro-gas & Oil field, Chemicals & Petrochemicals, Coal-mine, Metallurgy, Pharmacy, SMT, Fire-resistance, lab, Air diving, and so on

## Application (examples)

		<h3>Food</h3> <p>Sake</p>  <p>Frozen Food</p>  <p>Coffee</p>  <p>Snack</p>  <p>Jam Sauce for Yogurt</p>  <p>Rice cakes</p> 		<h3>Electronic</h3> <p>&lt;Surrounding Gas for Manufacturing Process&gt;</p>  <p>Semiconductor Manufacturing</p>
<h3>Metal</h3> 	<h3>Ceramic</h3> 	<h3>Machinery</h3>  <p>&lt;Enclosure Gas in Shock Absorber&gt;</p>	<h3>Resin Product</h3> <p>&lt;Antioxidant during Production&gt;</p> <p>Container</p>  <p>Film</p>  <p>Office Equipment Automobile Parts</p>  <p>Lenses</p> 	<h3>Medicine</h3> 

\* Hitachi bears no patent responsibility of the manufacturing equipment which use the gas. Do relevant research on user's side.

## Principle of Operation

The Nitrogen Generators are constructed according to the principle of operation P.S.A. (Pressure Swing Adsorption) and are composed by a minimum of two absorbers filled up with Carbon molecular sieve. The absorbers are crossed alternatively by the compressed air (previously purified in order to eliminate oil, humidity and powders) and produce nitrogen by removing Oxygen. While a container, crossed by the compressed air, produces gas, the other regenerates itself losing to pressure atmosphere the gases previously adsorbed. The process comes repeated in cyclical way. The generators are managed by a PLC.

# Nitrogen Plant Generator

- Flow: 10~3000 Nm<sup>3</sup>/h (100 lpm ~50000 lpm)
- Purity: ≥95% ~ 99.9995%
- Pressure: 0.1 ~ 8 bar (kg/cm<sup>2</sup>)
- Dew point: ≤-45 °C ~ 70C



## Our Reputed Customer



#### A divisions of Athena Technology



- 1.5ml HPLC Vials
- 9mm Bonded Cap & Septa
- 20mm Al Crimp Cap
- 250 µl Vial Insert
- HPLC Solvent Inlet Filter
- Crimper / Decrimper