

# Nitrogen Gas Generator GC



- N2 purifier to remove O2 and all other unwanted impurities to produce nitrogen up to UHP grade.
- Automatic heatless air dryer time based operation.
- Surge receiver with pressure regulator & valve inbuilt.
- Nitrogen, air gas with regulator, gauge and toggle valve (inbuilt) SS tank.
- Air filters for moisture, dust and oil, must removal (set of 2 filters).

### Silent Features:

- Deliver constant pressure & flow
- Fully Automatic Programmable System
- Easy Maintenance and space saving
- Effortless and easy operation
- Improves instrument performance
- CE & ISO 9001:2015 FDA Certified
- Fully regenerative, durability with PSA (pressure swing adsorption) technology
- CAD Detector

### Schematic Diagram of Gas Generator

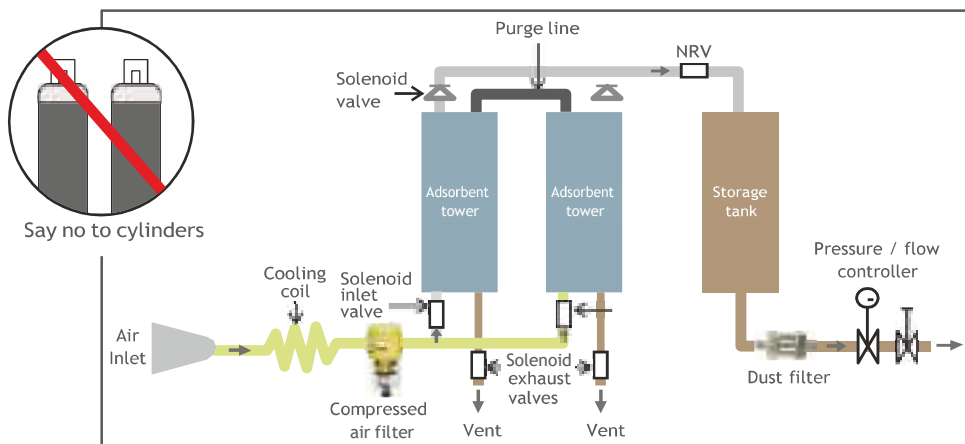

### Technical Specification

Model	Gas Output	Flow rate	Specification
ATN-03	Nitrogen Gas Generator	<p>Flow: N2 = 3000 ml/min (3 LPM)</p> <p>Purity: 99.99995%</p> <p>Pressure: 7-8 bar</p>	CE Marked Nitrogen Gas Generator with Inbuilt Air Compressor.

